

## Local Changes of Physical and Biological Parameters of the Sevastopol Bay Surface Waters under the Influence of Rain Drainage

A. V. Bagaev<sup>1</sup>, V. V. Nikishin<sup>1</sup>, T. V. Rauen<sup>2</sup>, L. V. Verzhetskaya<sup>1</sup>,  
S. V. Scherbachenko<sup>1</sup>

<sup>1</sup> Marine Hydrophysical Institute of RAS, Sevastopol, Russian Federation

<sup>2</sup> A. O. Kovalevsky Institute of Biology of the Southern Seas, Russian Academy of Sciences,  
Sevastopol, Russian Federation

✉ a.bagaev1984@mhi-ras.ru

### Abstract

**Purpose.** The work is aimed at assessing the temporal and spatial scales of variations in the physical and biological parameters of the seawater surface layer in the immediate vicinity of the urban rainwater drainage outlets in the Sevastopol Bay.

**Methods and Results.** The study area was limited to the Sevastopol Bay. Measurements were taken at the locations of the rainwater drainage outlets, namely in the Artilleriyskaya, Apollonova and Gollandiya bays. Temperature and salinity were measured by an unmanned surface vehicle (USV) using the TMA-21 sensor. The stations were located in a straight line normal to the coast from the rainwater drainage outlet. Quantitative and size composition of total suspended matter and bacterioplankton particles were determined using the Cytomics TM FC 500 flow cytometer. Water temperature was shown to vary within 1.5 °C and its horizontal gradient was weakly pronounced. In the salinity field, the gradient reached 0.5 m<sup>-1</sup>. The maximum concentrations of suspended matter were revealed in the apical part of the Artilleriyskaya Bay (about 0.5 × 10<sup>6</sup> particles mL<sup>-1</sup>). The particle sizes of suspended matter ranged from 0.5 to 2.5 μm. Bacterial concentrations in the storm water corresponded to the summer maximums observed in the Sevastopol Bay (0.9 × 10<sup>6</sup>–2.8 × 10<sup>6</sup> ppm). The storm water inflow into the bay resulted in changes of the picophytoplankton number (by 2–6 times).

**Conclusions.** The method of applying an unmanned surface vehicle for operative local monitoring of seawater state in the areas of the rainwater drainage outlets has been tested. The data on the salinity changes can serve as an indicator of the discharge intensity and can be used for forecasting the impact of storm water runoffs during reconstruction/relocation of the sewer network. The concentrations of suspended solids and microorganisms in the bay surface waters are restored one day after a heavy rain. Therefore, rapid assessment of the impact of potentially dangerous or accidental discharges requires application of the unmanned surface vehicles for conducting the operational measurements.

**Keywords:** Sevastopol Bay, storm water runoff, unmanned surface vehicle, seston, bacterioplankton, temperature, salinity

**Acknowledgements:** expeditionary research, data accumulation, and data quality assessment were supported by the RFBR and Sevastopol Government grant No. 20-45-920019. Additional data processing, its visualization, and analysis were performed within the framework of the state assignment of FRC MHI on theme No. 555-2021-0005. Processing of the flow cytometer data and analysis of the results were done with a support of the state assignment of FRC ISS No. 121030300149-0. The authors are grateful to V. S. Mukhanov and E. O. Sakhon for their assistance in cytometry process.

**For citation:** Bagaev, A.V., Nikishin, V.V., Rauen, T.V., Verzhetskaya, L.V. and Scherbachenko, S.V., 2022. Local Changes of Physical and Biological Parameters of the Sevastopol Bay Surface Waters under the Influence of Rain Drainage. *Physical Oceanography*, 29(2), pp. 152-171. doi:10.22449/1573-160X-2022-2-152-171

DOI: 10.22449/1573-160X-2022-2-152-171

© A. V. Bagaev, V. V. Nikishin, T. V. Rauen, L. V. Verzhetskaya, S. V. Scherbachenko, 2022

© Physical Oceanography, 2022



## Introduction

Due to the active urbanization of the coast, population growth, the presence of nature protection facilities, mariculture and recreation areas in the Sevastopol Bay, as well as due to the lack of a modern wastewater collection and treatment system, there is a need for new approaches to the management and operational monitoring of seawater quality. At the same time, due to the relatively short lifetime of the stormwater runoff plumes, sampling in research and monitoring expeditions is not always carried out during the lifetime of these plumes.

The study of the ecological state of bays, ports, and gulfs was carried out in many works [1–5]. As a rule, they analyze the chemical and biological state of sea waters averaged over sufficiently long periods of time, comprehensively assess the runoff nature and structure, and provide a forecast [6–9]. The works [10–14] are devoted to the problem of assessing the ecological state of the Black Sea coastal waters. The study of water pollution in the Sevastopol Bay and the coastal zone adjacent to it was carried out earlier in [15–21] on the basis of long-term monitoring data at stations in the deep-water part of the bay. It has been shown that the discharge of untreated waters leads to negative changes in the living conditions of hydrobionts, a decrease in their number, species diversity [22, 23], as well as to mass phytoplankton blooms, formation of hypoxia zones in the bottom layer, and general degradation of the Sevastopol Bay ecosystem [24–26]. It should be noted that recent studies performed with the use of modern methods for assessing the state of natural systems characterize the ecological status of the Sevastopol Bay as critical [27]. The sewer networks of the city cannot cope with the volumes of extreme storm runoff caused by climatic and infrastructure variability in the region [21]. Based on a numerical model, in [28] it was demonstrated that dissolved and particulate matter carried along with storm runoff can affect adjacent coastal areas for several days. In it, the admixture was assumed to be conservative, since there were no objective estimates of the lifetime of microplumes formed as a result of storm sewer outlets.

A specific indicator of the seawater quality and the state of their ecosystems is concentration of the main components of suspended matter (organic and mineral substances). According to the data of [14], 1680 tons of particulate matter from 1 km<sup>2</sup> of urban development area annually enters the Sevastopol Bay. Taking into account recent trends in population growth and an increase in the construction area, this figure can be significantly higher <sup>1</sup>. In the surface layer of water, due to low salinity and density, the plume quickly spreads and is easily identified by visual methods due to its color.

Important markers of particulate matter, which provide the assessment of water pollution degree, are the dimensional, quantitative and qualitative composition of particulate matter. Rapid evaluation of these particulate markers contained in the storm drains and receiving marine waters can be obtained using the flow cytometry (FC) method. This is one of the high-tech methods for studying disperse media in the mode of individual analysis of individual particles (i.e., the dispersed phase)

---

<sup>1</sup> *The law of Sevastopol of July 18, 2017 no. 357 “On the Approval of the Strategy of the Socio-economic Development of the Sevastopol until 2030”.* Available at: <https://sev.gov.ru/files/strategy/357-zs.pdf> [Accessed: 15 February 2022] (in Russian).

using light scattering and fluorescence signals. The first works devoted to the analysis of suspended matter using FC in estuary waters were carried out in the 1990s [29, 30]. Subsequently, modernization of the technical characteristics of the instruments provides the expansion of the scope of this method [31]. In particular, today, using FC, it is possible to study the dispersive properties of storm runoffs measured particulate matter concentrations and identify plumes in the water area of the bays. This method allows not only to carry out a general quantitative analysis of particulate matter (seston, SM), including microorganisms and non-living particles (detrital and mineral) but also to isolate information about individual components of seston – heterotrophic bacterioplankton and picophytoplankton, key microbial components of the marine coastal ecosystem. This makes it possible to assess the effect of stormwater on the picoplankton structure of the bay. Monitoring of the suspended matter spatial-temporal variability serves as an instrument for studying the dynamics of a stormwater plume, its distribution over the water area, and the impact on the microbial population of the pelagic zone.

Existing surface and land unmanned vessels perform both scientific and technical work in water areas and coastal areas ([www.asvglobal.com](http://www.asvglobal.com), [www.ceehydrosystems.com](http://www.ceehydrosystems.com), [www.yunzhou-tech.com](http://www.yunzhou-tech.com), [clearpathrobotics.com/heron-unmanned-surface-vessel](http://clearpathrobotics.com/heron-unmanned-surface-vessel)). The publications of the Saildrone company ([www.saildrone.com](http://www.saildrone.com)) present the results of the application of unmanned surface robots to record the acoustic signals of ocean inhabitants. A common feature of most coastal studies is the use of robotic unmanned devices in bathymetric surveys in water areas. With rare exceptions, the works describing the unmanned surface vehicles (USV) listed above do not provide information on the use of temperature and salinity sensors for expeditionary research.

Among Russian projects, one can note the successful design of an unmanned vehicle of the Center for Marine Research of Moscow State University <sup>2</sup>. There are fewer publications devoted to the use of surface unmanned vessels in environmental monitoring tasks [32, 33]. There is only one successful project of this type based on anchored buoys in Sevastopol (the WatSen Private Company, [www.watsen.info](http://www.watsen.info)). The Avionicus Company, together with Karelian Research Center, announced the operation of its USV in the lakes of Karelia <sup>3</sup>.

It is also worth noting that a large number of publications about USV are devoted to the development of a control system, control algorithms, and hardware: the development of the hull and control system was carried out in [34], a modular system with automated detection of marine debris is proposed in [35]. Prototypes of an automated laboratory for small water bodies are shown in [36, 37].

An automated study of the plumes of small rivers with the help of unmanned aerial vehicles, similar in methodology, is given in [38, 39].

---

<sup>2</sup> Avionicus, 2015. *AM5 [Unmanned Underwater Vehicle. Technical description and user manual]* Available at: [http://resources.krc.karelia.ru/water/doc/noc/am5\\_avionicus\\_usv\\_ru.pdf](http://resources.krc.karelia.ru/water/doc/noc/am5_avionicus_usv_ru.pdf) [Accessed: 04 March 2022] (in Russian).

<sup>3</sup> LMSU MRC, 2020. [*Testing of the Final Version of the Prototype of the Marine Unmanned Robotic Vehicle*]. Available at: <https://marine-rc.ru/novosti/ispytaniya-finalnoy-versii-prototip> [Accessed: 04 March 2022] (in Russian).

The experimental part of the work is devoted to the monitoring of *in situ* water hydrophysical properties using USV and instrumental measuring instruments. The use of a precision conductometer TMA-21<sup>4</sup> for measuring electrical conductivity in areas of storm drains is considered. A distinctive feature of the performed expeditionary work is the use of the original USV as a conductometer carrier, which made it possible to obtain a significant amount of measurements in a short time. The performed field studies clearly demonstrate the advantages of using unmanned vehicles for contact measurements of water parameters. The developed complex as a part of the USV and the integrated measuring systems makes it possible to fix the measurement of electrical conductivity to geographical coordinates, which ultimately provides the construction of a two-dimensional field of distribution and variation in electrical conductivity in the runoff area.

The author-developed USV [40–43], which we use, is smaller in size than those listed above, consequently, on the one hand, it improves the mobility of coastal expeditions, and, on the other hand, it introduces some restrictions on operating conditions (wind-wave conditions on the water).

The purpose of this work is to assess the temporal and spatial scales of changes in the physical and biological parameters of the seawater surface layer in the immediate vicinity of the storm runoff outlet of the city sewer network.

Two tasks were solved in the study: first, it was required to estimate the lifetime and propagation range of rain runoff microplumes; secondly, to show that unmanned vehicles are a reliable instrument for carrying out operational measurements directly during rain.

### Materials and methods

The study area was limited by the Sevastopol Bay (Sevastopol, southwestern part of the Crimean Peninsula, Russia). Three well-known outlets of storm sewers were selected for the study: in Artilleriyskaya, Apollonova, and Gollandiya Bays (Fig. 1). From February to July 2021, near each outlet water samples were taken at four stations located normal to the coast (Fig. 2). The sampling period included the following periods (see the Table): no precipitation (background values); during or immediately after the rain; the next day after the rain. Simultaneously with sampling, the temperature and salinity of the seawater on the surface were measured using the USV of the original design, while moving in tacks along and across the testing site, using the TMA-21 sensor. Due to weather conditions and poor GPS signal, temperature and salinity measurements with the USV were not carried out in all expeditions (see the last column in the Table).

---

<sup>4</sup> Planeta Info, Ltd., 2019. [*Conductivity Sensor (Salinity, Mineralization) TMA-21*]. Available at: <https://datchiki.com/wp-content/uploads/2019/08/Datchik-provodimosti-TMA-21-s.pdf> [Accessed: 04 March 2022] (in Russian).

## Consolidated list of expeditions to the areas of storm water runoffs in the Sevastopol Bay in 2021

Date	Location of the expedition	Weather conditions	Measurement results
26.03.2021	Apollonova Bay	after the rain	No results. Reason: mechanical damage to the autopilot board
02.04.2021	Apollonova Bay	calm	Water temperature and salinity
08.04.2021	Artilleriyskaya Bay	during the rain	Water temperature and salinity
09.04.2021	Artilleriyskaya Bay	after the rain	No results. Reason: flooding of the autopilot body due to rain during transportation
29.04.2021	Artilleriyskaya Bay	calm	No results. Reason: weak signal of GNSS
17.05.2021	Apollonova Bay	after the rain	No results. Reason: strong surface waves
03.06.2021	Gollandiya Bay	during the rain	No results. Reason: insufficient tightness of the autopilot body
04.06.2021	Gollandiya Bay	after the rain	No results. Reason: mechanical failure of the impeller
07.06.2021	Gollandiya Bay	calm	Water temperature and salinity
18.06.2021	Gollandiya Bay	after the rain	Water temperature and salinity

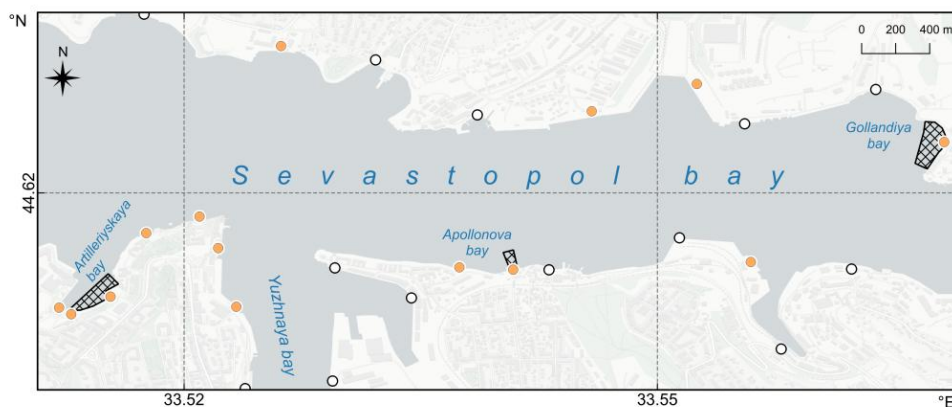

**Fig. 1.** Schematic map of the Sevastopol Bay central part with the marks corresponding to the known locations of the rainwater (orange dots) and municipal (white dots) wastewater discharge outlets. Crosshatched polygons show the areas of expeditions: the Artilleriyskaya, Apollonova and Gollandiya Bays. The map is built using QGIS 3.10 software and cartoDB Positron basemap

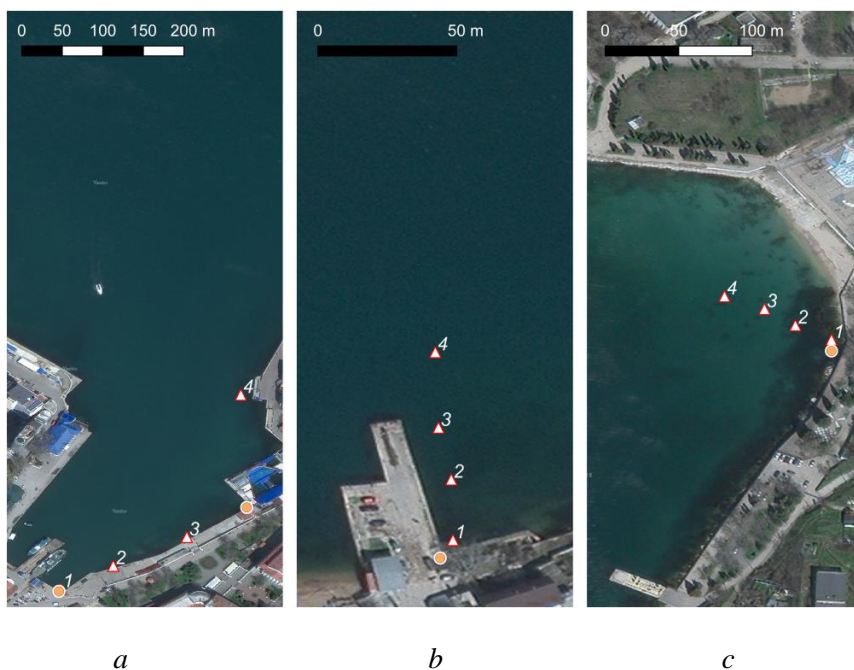

**Fig. 2.** Scheme to show location of the water sampling stations 1–4 (red-white triangles) with the marks corresponding to the known locations of the rainwater (orange dots) discharge outlets in the study areas: *a* – the Artilleriyskaya Bay; *b* – the Apollonova Bay; *c* – the Gollandiya Bay. The map is built using QGIS 3.10 software and Yandex-satellite basemap

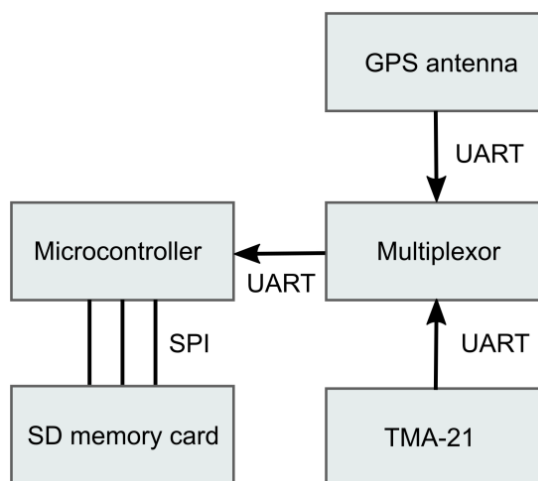

*a*

*b*

**Fig. 3.** Overview of USV (*a*) and functional scheme of the TMA-21 conductometer converter (*b*). UART – Universal Asynchronous Receiver and Transmitter, SPI – serial peripheral interface

During the expeditions, the following devices were used:

- an unmanned surface vehicle with  $1 \times 0.3 \times 0.5$  m dimensions, equipped with an autopilot, a TMA-21 temperature and electrical conductivity sensor, and a GNSS module (Fig. 3, a);
- an Inzer-250 double rubber inflatable boat, a waterproof battery 12 V;
- a ground station (an ASUS laptop with an external telemetry module) for monitoring the operation of the USV and devices.

Sampling for cytometric analysis in the laboratory was carried out in parallel with the USV work, which together made it possible to reduce the time for one expeditionary exit. When sampling, the rules regarding sterility of containers and fixing the sampling points using a navigator were followed.

The stations were located on a straight line normal to the shore from the storm sewer outlet at a distance of 5, 20, 50, 100 m (where the shore morphology allowed it).

Using the USV, a hydrological study of the work site was carried out (measurement of temperature and salinity). The data from the USV were sent to the ground station for control. After passing through all the stations, the USV returned to the launch site. The direction and placement of the lines was chosen so that they were covered by the measurements of the water sampling station with up to 50 m capture in both directions.

Processing of temperature and salinity measurement data (filtering by quality and interpolation by the method of inverse weighted distance (Inverse Distance Weighted<sup>5</sup>, IDW) was performed in the QGIS geographic information system.

The horizontal resolution is determined by the USV speed and discreteness of the reception of coordinates. Due to the fact that the reception of coordinates is carried out with 1 Hz frequency, the minimum distance between the nearest measurements is equal to the USV speed. During the expeditionary work, the speed of the apparatus did not exceed  $1.5 \text{ m}\cdot\text{s}^{-1}$ . Thus, along the tack line, the resolution is  $\sim 1.5$  m.

Water samples were analyzed using Cytomics TM FC 500 flow cytometer (Beckman Coulter, USA) and CXP software. To determine the quantitative and size composition of the total suspended matter particles, a special measurement protocol was developed [44]. The total abundance of SM was determined in unstained water samples by gating the particle population on two-parameter direct light scatter (FS channel) and granularity (SS) cytograms. The number of bacteria was determined in samples stained with SYBR Green I (Molecular Probes, USA) in accordance with [45] using cell population gating on two-parameter direct light scattering cytograms (FS channel) and SYBR Green I fluorescence in the green spectral region (FL1 channel, 525 nm) on dimensionless logarithmic scales [46]. The number/amount of bacterioplankton cells was calculated from the sample flow rate ( $15 \mu\text{l}\cdot\text{min}^{-1}$ ), counting time (60 s), and the number of cells registered during this time period (3000–50000 cells). The quality control of the measurements was

---

<sup>5</sup> QGIS Development Team, 2020. *QGIS User Guide. 24.1.4. Interpolation*. Available at: [https://docs.qgis.org/3.16/en/docs/user\\_manual/processing\\_algs/qgis/interpolation.html](https://docs.qgis.org/3.16/en/docs/user_manual/processing_algs/qgis/interpolation.html) [Accessed: 04 March 2022] (in Russian).

performed using calibration fluorospheres Flow-Check TM (Beckman Coulter) with a known concentration in the sample.

The total abundance of picoplankton was determined in unstained samples by gating the cell population on two-parameter direct light scattering cytograms (FS channel) and autofluorescence in the red (FL4, 675 nm) and orange (FL2, 575 nm) regions of the spectrum on dimensionless logarithmic scales.

Identification of picocyanobacteria clusters of *Synechococcus* genus and pico-eukaryotic algae in the space of cytometric variables was carried out by cell size (FS channel) and orange fluorescence (FL2 channel) of phycoerythrin (PE) in accordance with [47].

## Results

During the analysis of the USV practical application in field studies, the main limitations were identified: low splash protection of the autopilot controller board (flooding during the rain and condensate separation from breaking wind waves), low stability during waves and low sensitivity of the GPS antenna, especially in the presence of nearby interference sources. At the same time, the batteries performed well (stable operation for two hours, sufficient power reserve), telemetry transmission channel and data storage system on board (zero losses).

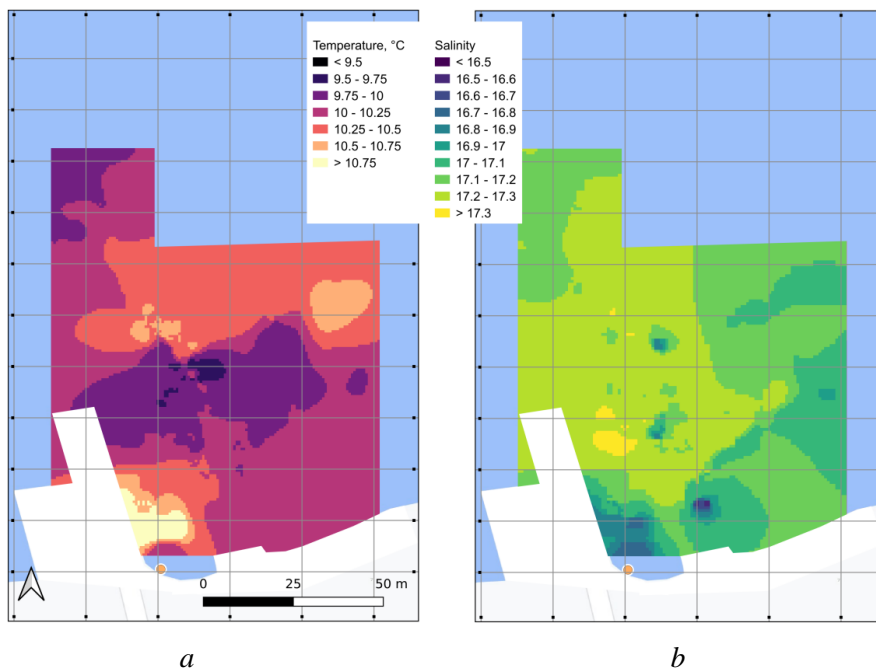
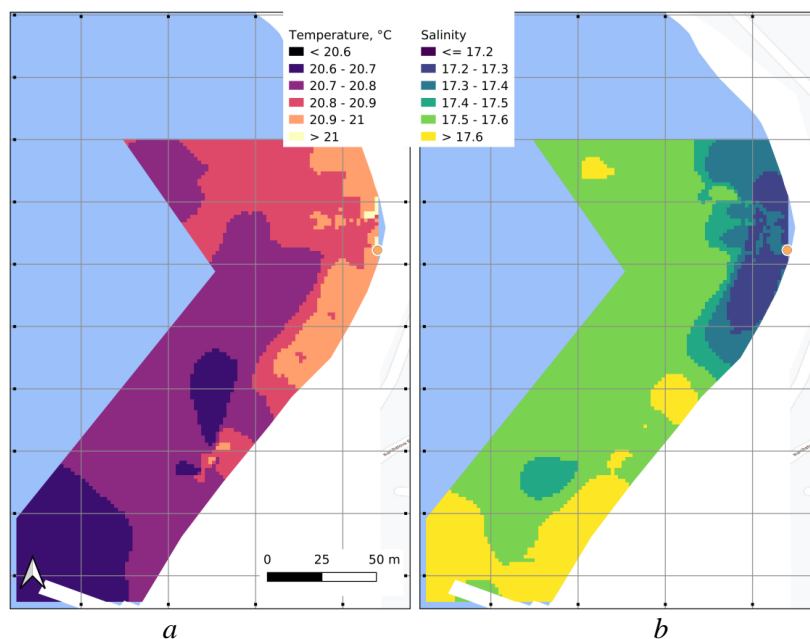

**Fig. 4.** Two-dimensional temperature (a) and salinity (b) field based on the *in situ* measurements performed by the TMA-21 sensor from aboard the USV near the rainwater discharge outlet in the Apollonova Bay on 02.04.2021. The result of IDW interpolation made using QGIS and Google Terrain basemap. Location of the rainwater discharge outlet is shown by an orange dot. Grid lines are drawn with the 20 m interval



The temperature field turned out to be the least informative parameter in assessing local changes in the physical parameters of the sea water surface. As a rule, temperature changes did not exceed  $0.5^{\circ}\text{C}$  and only for the Apollonova Bay reached  $1.25^{\circ}\text{C}$  during the measurements in April (Fig. 4, *a*). The strongest gradients have always been concentrated near the coast. At the same time, in the shallow Gollandiya Bay, in the shallowest area, where the bottom is densely overgrown with macrophytes and has a dark color (Fig. 2, *c*), as a result of differential heating, a higher temperature was consistently observed compared to the deep-water part of the bay (Fig. 5, *a*). In the Apollonova and Artilleriyskaya Bays, the bottom has a sharper slope, the coast is concreted. In most cases, lower temperatures were noted near concrete piers and local patches of warm water at storm sewer outlets (Fig. 4, *a*; 6, *a*).

The salinity field in all expeditions corresponded to the expected distribution with a positive gradient towards the open part of the bay. On all maps of the salinity field (Fig. 4, *b*; 5, *b*; 6, *b*) one can observe spots of slightly desalinated water in the immediate vicinity of the storm sewer outlet. During the measurements carried out during the rain (the Artilleriyskaya Bay, Fig. 6, *b*), the gradient was  $\sim 0.5 \text{ m}^{-1}$ . Thus, by operational measurements of the seawater physical parameters using the USV, it is possible to identify and localize the sources of desalinated water in the bay with sufficiently high accuracy. Note that the distribution of the salinity gradient indicates rapid mixing of the upper water layers during the plume propagation.



**Fig. 5.** Two-dimensional temperature (*a*) and salinity (*b*) field based on the *in situ* measurements performed by TMA-21 sensor from the board the USV near the rainwater discharge outlet in the Gollandiya Bay on 18.06.2021. The result of IDW interpolation made using QGIS and Google Terrain basemap. Location of the rainwater discharge outlet is shown by an orange dot. Grid lines are drawn with the 40 m interval

Temperature and salinity measurements showed a slight positive gradient in temperature and salinity away from the coast, which is in good agreement with the assumption of relatively rapid mixing.

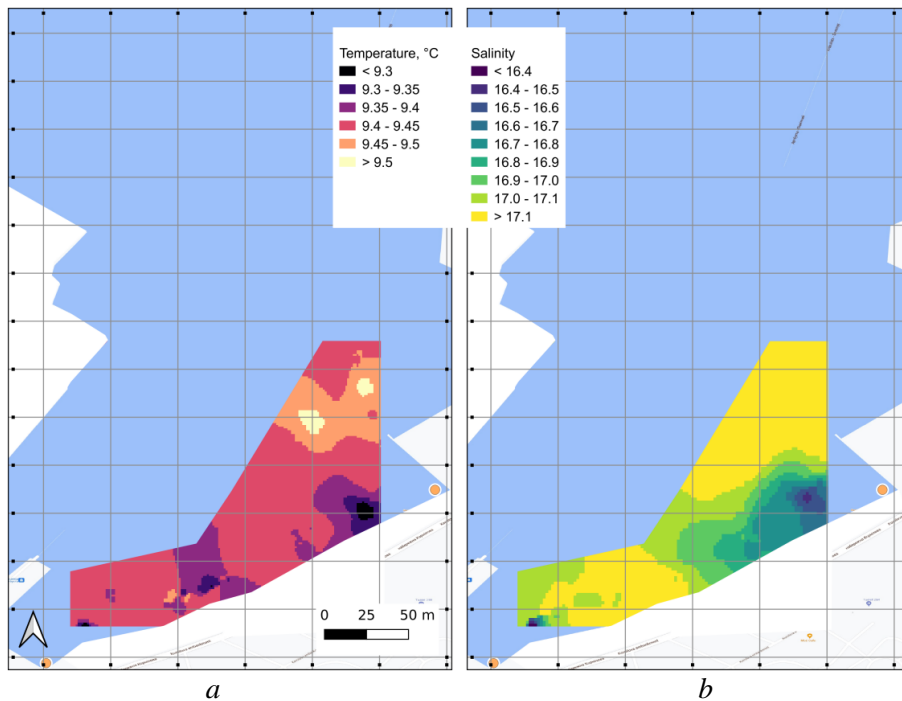
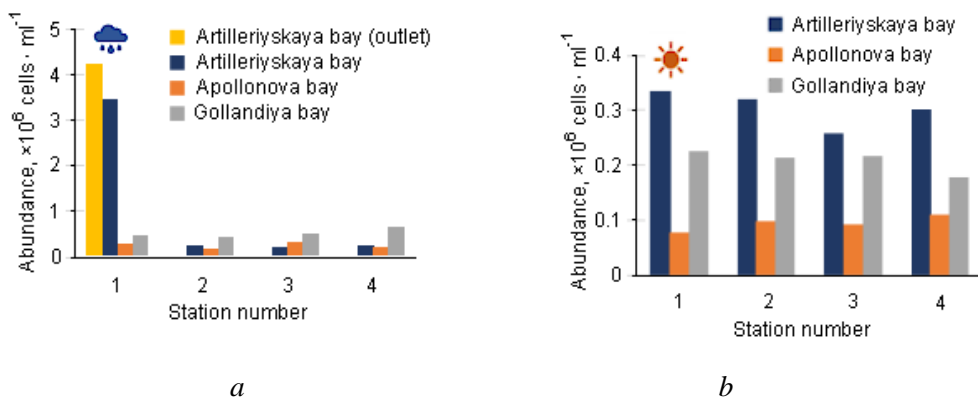

**Fig. 6.** Two-dimensional temperature (*a*) and salinity (*b*) field based on the *in situ* measurements performed by TMA-21 sensor from the USV board near the rainwater discharge outlet in the Artilleriyskaya Bay on 08.04.2021. The result of IDW interpolation made using QGIS and Google Terrain basemap. The location of the rainwater discharge outlet is shown by an orange dot. Grid lines are drawn with the 40 m interval

Direct measurements on small scales and with high time and space resolution were carried out for the first time in the Sevastopol Bay using the USV. The results of our measurements are in good agreement with previous works on numerical modeling of pollutants propagation in the Sevastopol Bay (see, for example, [28, 48, 49]). A characteristic feature of all these works was the calculation of a passive tracer propagation from a point source with an initial concentration taken as unity. Although the further propagation of the tracer is determined by a complex system of currents in the bay, one common feature can be noted: as early as 24 h after the tracer release, its concentration at the minimum distance from the initial point decreases to  $\sim 5\%$  of the initial one (see Fig. 1 from [49], the first map in the second row or Fig. 6, *b* from [28]). On the other hand, in [48], using numerical simulations, it was demonstrated what a determining influence the Chernaya River runoff has on the thermohaline structure of the Sevastopol Bay waters (average monthly maximum up to  $3.5 \text{ m}^3 \cdot \text{s}^{-1}$  according to [50]; the maximum discharge  $15.2 \text{ m}^3 \cdot \text{s}^{-1}$  according to [17]). As noted in [17], the river waters do not even enter the water area of the Inkermansky Kovsh, i.e. they do not penetrate further than 3 km from the place of confluence. From the totality of model data and

observations, it is possible to draw a preliminary conclusion about the local nature of the influence of any sources with a flow rate lower than the flow rate of a minor river during the flood period ( $\sim 5 \text{ m}^3 \cdot \text{s}^{-1}$ ) on the content of impurities in the bay water. At the same time, it is certainly necessary to take into account that, depending on the dissolved contaminant chemical composition, the degree of negative impact on the ecological state of the water area can be significantly increased.

*Suspended matter.* When analyzing the obtained data, it was found that during the rain the maximum amount of suspended particles is determined at st. 1 in the Artilleriyskaya Bay waters ( $\sim 3.5 \times 10^6 \text{ part} \cdot \text{ml}^{-1}$ ), directly near the storm drain (Fig. 7, *a*), while the SM concentration in the stormwater directly entering the bay was  $\sim 4.3 \times 10^6 \text{ part} \cdot \text{ml}^{-1}$ , i.e. in the surface layer of the bay, the concentration of suspended particles decreases as a result of stormwater dilution in the plume. It should be noted that the SM abundance concentration in the Artilleriyskaya Bay compared to other stations (the Apollonova and Gollandiya Bays) was higher not only during the rain, but also every other day, as well as during a long period without the rain (Fig. 7, *b*). Thus, according to this indicator, it can be argued that the Artilleriyskaya Bay receives and retains the largest amount of terrigenous suspended matter.



**Fig. 7.** Dynamics of the seston abundance at the stations in three bays (the Artilleriyskaya, Apollonova and Gollandiya ones) during the rain (*a*) and in its absence for a long time (background values) (*b*)

The dynamics of SM distribution at the stations in the three bays was different. Perhaps this is due to the intensity of runoff, currents, and depth. During the rain in the Artilleriyskaya Bay, already at st. 2, the SM concentration was an order of magnitude lower ( $0.5 \times 10^6 \text{ part} \cdot \text{ml}^{-1}$ ) than at st. 1 ( $3.5 \times 10^6 \text{ part} \cdot \text{ml}^{-1}$ ) and almost corresponded to the background values (Fig. 7). In the Gollandiya and Apollonova Bays, on the contrary, an increase in the suspended matter concentration was noted during the rain at stations located far from the storm drain. In general, the SM distribution at the stations was more uniform (Fig. 7, *a*). The difference in the dynamics of SM distribution at the stations in different bays persisted before, during, and after the rain (Fig. 8).

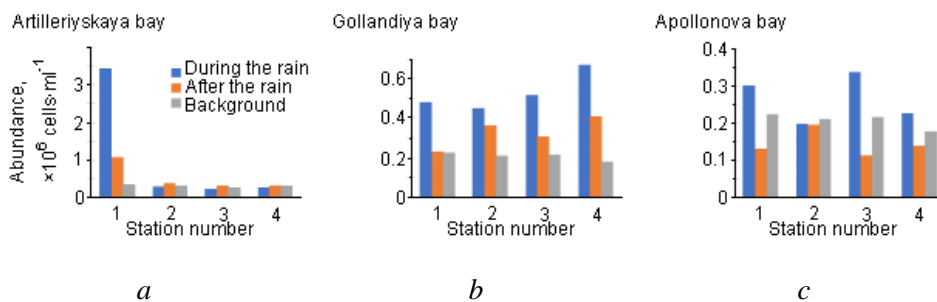

**Fig. 8.** Dynamics of the seston abundance at the stations in three bays before, during, and after the rain

*Bacterioplankton.* As it turned out, bacteria concentrations in stormwater corresponded to the summer maximums of the bacterioplankton content observed in the Sevastopol Bay and amounted to  $0.9 \times 10^6$ – $2.8 \times 10^6$  cells·ml<sup>-1</sup> (Fig. 9, a). At the same time, at all stations, they were somewhat lower than the background values observed in the same water areas before the rain (Fig. 9, b). That is, during the rain the bacteria concentration in the surface layer of the bay decreased, and then the next day after the rain it began to recover, which is clearly seen in the example of the Artilleriyskaya Bay (Fig. 9, b). This indicated the impact of stormwater on the microbial population of the receiving marine area.

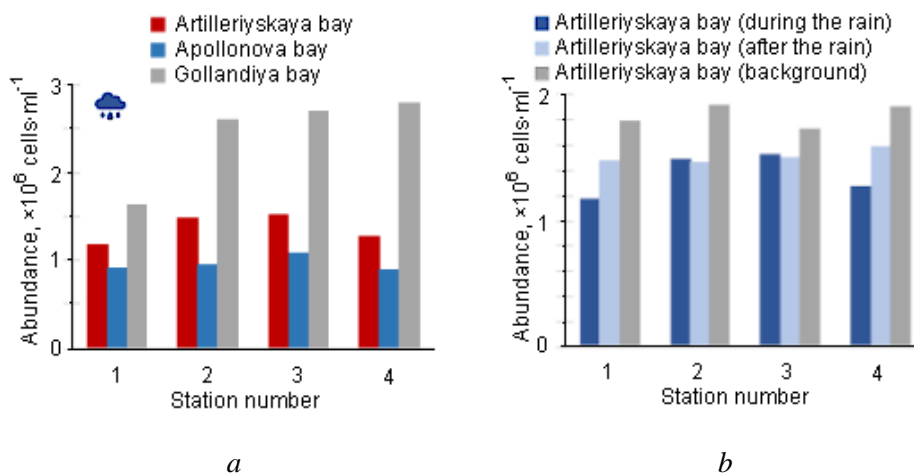

**Fig. 9.** Dynamics of the bacterial plankton abundance: a – during the rain at the stations in three bays; b – in the Artilleriyskaya Bay before, during, and after the rain

Similar effects were previously noted by other authors in the studies of estuarine zones subject to anthropogenic pollution [51–53]. The abundant stormwater discharge into the marine area leads to its significant freshening and introduces an excess of suspended matter, nutrients, and its own microflora into it. Such a strong impact on the resident microbial community can trigger successional processes in it, and returning to the “normal” state requires a significant time [52].

During the rainy season, the composition of bacterioplankton in the receiving waters usually changes dramatically: the taxonomic diversity of the community increases, the spatial heterogeneity in the distribution of microorganisms decreases, phylogenetic analysis reveals a larger number of freshwater and terrestrial taxa, as well as an increase in the proportion of bacteria pathogenic for humans [51].

Significant changes in the abundance of bacterioplankton, revealed in this study during the abundant stormwater discharge into the semi-enclosed marine area, could just indicate such changes in the resident bacterial community. The return of its quantitative indicators to the norm (equilibrium state) a day after the disturbance, however, could not serve as an indicator of the end of successional processes.

*Picophytoplankton.* The cytometric analysis did not reveal representatives of picoplankton directly in storm waters, which was quite expected. In the Artilleriyskaya Bay, heavy rain did not cause noticeable changes in the abundance of picophytoplankton, with the exception of an increase in the abundance of *picocyanobacteria* (*Syn*) at st. 1, directly near the location of the storm drain (Fig. 10, *a*), which may be due to the entry of biogenic substances (primarily nitrites, which are actively utilized by pico-cyanobacteria) into the bay waters, or to the fact that cyanobacteria reproduce better in slightly saline water.

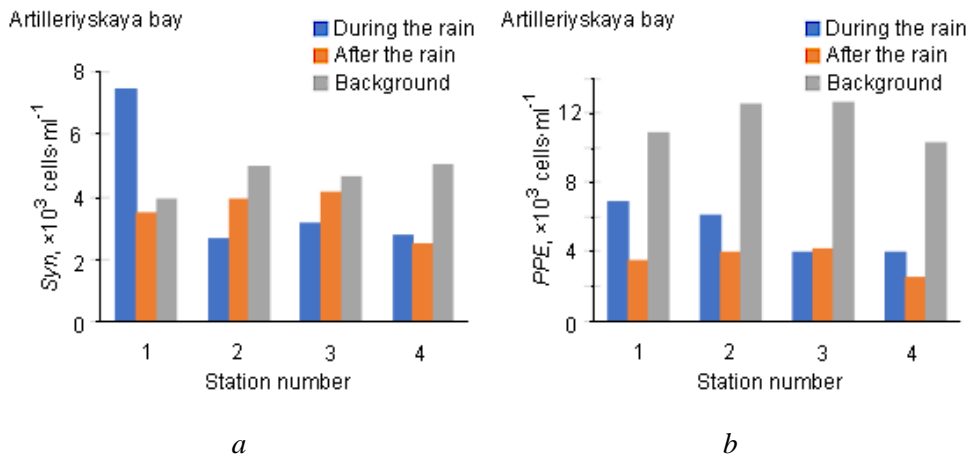

**Fig. 10.** Dynamics of the pico-cyanobacteriae *Synechococcus* (*Syn*) (*a*) and eukaryotic pico-algae (PPE) (*b*) abundance at the stations in the Artilleriyskaya Bay before, during, and after the rain

As noted in other publications, this group of microorganisms is able to increase in numbers in the areas of wastewater discharges [53]. On the contrary, the number of PPE decreased in response to the stormwater inflow (Fig. 10, *b*), however, the interpretation of our data is difficult due, firstly, to their insufficient volume and, secondly, to the poor knowledge of the ecology and ecophysiology of the smallest eukaryotic phytoplankton.

*The sizes of suspended particles* at the transect stations in the Artilleriyskaya Bay, Apollonova Bay, and the Gollandiya Bay before, during, and after the rain differed significantly. During rain, the highest SM particle sizes were recorded at almost all stations in the Apollonova Bay. The background values in this bay were almost two times lower than those recorded during precipitation. That is, the influx of storm water led to an increase in the SM particle size. The opposite situation was observed in the Artilleriyskaya Bay: during the rain at st. 1, directly next to the drain, the particle size was twice smaller ( $0.8 \mu\text{m}$ ) than in the long absence of precipitation ( $1.7 \mu\text{m}$ ). The maximum and minimum SM particle sizes were recorded during the rain in the Apollonova Bay ( $2.4 \mu\text{m}$ ) at st. 2 and in the Artilleriyskaya Bay ( $0.8 \mu\text{m}$ ).

### Conclusions

1. A technique for the use of unmanned surface vehicles for operational monitoring of the seawater state in the areas of sewer outlets has been built and tested. Omissions in measurements caused by unstable operation of the GPS receiver and flooding of the equipment with rain and waves indicate the need for further refinement of the GNSS housing and antennas.

2. Slight changes in the seawater temperature (within  $1.5^{\circ}\text{C}$ ) were recorded even during precipitation. The temperature gradient almost always corresponded to the bathymetry. Thus, water temperature is not a sufficiently informative indicator of changes in the water state during storm runoff in shallow water under conditions of rapid mixing.

3. More significant changes were observed in the salinity field (within  $1 \text{ m}^{-1}$ ), with a gradient reaching 0.5 at  $\sim 1 \text{ m}$ . Salinity variation data can serve as an indicator of the stormwater runoff intensity and can be used to predict the potential impact of stormwater in a city's sewer refurbishment/relocation.

4. The maximum concentrations of suspended matter were measured in the upper part of the Artilleriyskaya Bay ( $\sim 0.5 \times 10^6 \text{ part} \cdot \text{ml}^{-1}$ ). The dynamics of seston distribution at stations in different bays differed, and this difference persisted before, during, and after rain.

5. The bacteria concentrations in the stormwater corresponded to the summer maxima of bacterioplankton observed in the Sevastopol Bay ( $0.9 \times 10^6$ – $2.8 \times 10^6 \text{ cells} \cdot \text{ml}^{-1}$ ). The stormwater inflow into the bay water area led to a slight decrease in the abundance of bacterioplankton at all stations and contributed to the changes in the picoplankton abundance, which were different in each bay. The background values of suspended matter and microorganisms' content in the Sevastopol Bay waters were restored a day after heavy rain.

6. The constructed maps of salinity distribution and plots of changes in seston concentration qualitatively correspond to the results of earlier numerical modeling for the Sevastopol Bay and can be used to select the coefficients of horizontal turbulent mixing in numerical models.

## REFERENCES

1. Kumar, P., 2021. Water Quality Assessments for Urban Water Environment. *Water*, 13(12), 1686. <https://doi.org/10.3390/w13121686>
2. Costanzo, S.D., O'Donohue, M.J., Dennison, W.C., Loneragan, N.R. and Thomas, M., 2001. A New Approach for Detecting and Mapping Sewage Impacts. *Marine Pollution Bulletin*, 42(2), pp. 149-156. [https://doi.org/10.1016/S0025-326X\(00\)00125-9](https://doi.org/10.1016/S0025-326X(00)00125-9)
3. Chunye, W. and Delu, P., 2017. Zoning of Hangzhou Bay Ecological Red Line Using GIS-Based Multi-Criteria Decision Analysis. *Ocean & Coastal Management*, 139, pp. 42-50. <https://doi.org/10.1016/j.ocecoaman.2017.01.013>
4. Özdemir, N., Döndü, M. and Doğan, H.M., 2018. Investigation Some Physico-Chemical Properties of the Freshwater Sources Feeding the Bay of Gökova in Turkey by Geographic Information Systems. In: S. A. Maskevich and S. S. Poznyak, eds., 2018. *Sakharov Readings 2018: Environmental Problems of the XXI Century*. Minsk: IVTZ Minfina, pp. 12-14. Available at: <https://elib.bsu.by/handle/123456789/204106> [Accessed: 01 March 2022].
5. Konovalov, S., Vladymyrov, V., Dolotov, V., Sergeeva, A., Goryachkin, Yu., Vnukov, Yu., Moiseenko, O., Alyemov, S., Orekhova, N. and Zharova, L., 2011. Coastal Management Tools and Databases for the Sevastopol Bay (Crimea). In: E. Ozhan, ed., 2011. *Proceedings of the Tenth International Conference on the Mediterranean Coastal Environment, MEDCOAST 11*. Rhodes, Greece. Vol. 1, pp. 145-156. Available at: [https://istina.msu.ru/media/publications/articles/310/75b/4422893/MedCoast\\_Rhodes.pdf](https://istina.msu.ru/media/publications/articles/310/75b/4422893/MedCoast_Rhodes.pdf) [Accessed: 20 April 2022].
6. Penna, P., Baldrighi, E., Betti, M., Bolognini, L., Campanelli, A., Capellacci, S., Casabianca, S., Ferrarin, C., Giuliani, G. [et al.], 2021. Water Quality Integrated System: A Strategic Approach to Improve Bathing Water Management. *Journal of Environmental Management*, 295, 113099. <https://doi.org/10.1016/j.jenvman.2021.113099>
7. Reynolds, L.J., Martin, N.A., Sala-Comorera L., Callanan K., Doyle P., O'Leary C., Buggy P., Nolan T.M., O'Hare G.M.P. [et al.], 2021. Identifying Sources of Faecal Contamination in a Small Urban Stream Catchment: A Multiparametric Approach. *Frontiers in Microbiology*, 12, 661954. doi:10.3389/fmicb.2021.661954
8. Graves, C.A., Powell, A., Stone, M., Redfern, F., Biko, T. and Devlin, M., 2021. Marine Water Quality of a Densely Populated Pacific Atoll (Tarawa, Kiribati): Cumulative Pressures and Resulting Impacts on Ecosystem and Human Health. *Marine Pollution Bulletin*, 163, 111951. <https://doi.org/10.1016/j.marpolbul.2020.111951>
9. Meng, F. and Saagi, R., 2021. Integrated Modelling and Control of Urban Wastewater Systems. In: X. C. Wang and G. Fu, 2021. *Water-Wise Cities and Sustainable Water Systems: Concepts, Technologies, and Applications*. London: IWA Publishing. Chapter 10, pp. 259-279. [https://doi.org/10.2166/9781789060768\\_0259](https://doi.org/10.2166/9781789060768_0259)
10. Yalçın, B., Artüz, M.L., Pavlidou, A., Çubuk, S. and Dassenakis, M., 2017. Nutrient Dynamics and Eutrophication in the Sea of Marmara: Data from Recent Oceanographic Research. *Science of The Total Environment*, 601-602, pp. 405-424. <https://doi.org/10.1016/j.scitotenv.2017.05.179>
11. Tan, İ. and Aslan, E., 2020. Metal Pollution Status and Ecological Risk Assessment in Marine Sediments of the Inner Izmit Bay. *Regional Studies in Marine Science*, 33, 100850. <https://doi.org/10.1016/j.rsma.2019.100850>
12. Moiseenko, O.G., Konovalov, S.K. and Orekhova, N.A., 2013. [Indices for Assessing the Ecological Status of Bays in the Overall Strategy for Managing the Coastal Environment for its Sustainable Development on the Example of the Sevastopol Bay (Black Sea)]. In: MHI,

2013. *Ekologicheskaya Bezopasnost' Pribrezhnykh i Shel'fovykh Zon i Kompleksnoe Ispol'zovanie Resursov Shel'fa* [Ecological Safety of Coastal and Shelf Zones of Sea and Comprehensive Use of Shelf Resources]. Sevastopol: ECOSI-Gidrofizika. Iss. 27, pp. 399-402 (in Russian).
13. Tereshchenko, N.N., Proskurnin, V.Yu., Gulin, S.B. and Krylova, T.A., 2013. [Radioecological Monitoring of Plutonium in the Bottom Sediments of Sevastopol Bays]. In: MHI, 2013. *Ekologicheskaya Bezopasnost' Pribrezhnykh i Shel'fovykh Zon i Kompleksnoe Ispol'zovanie Resursov Shel'fa* [Ecological Safety of Coastal and Shelf Zones of Sea and Comprehensive Use of Shelf Resources]. Sevastopol: ECOSI-Gidrofizika. Iss. 27, pp. 289-293 (in Russian).
  14. Mironov, O.A., Muravyova, I.P. and Mironova, T.O., 2012. Oil Pollution of Sevastopol Coasts. In: MHI, 2012. *Ekologicheskaya Bezopasnost' Pribrezhnykh i Shel'fovykh Zon i Kompleksnoe Ispol'zovanie Resursov Shel'fa* [Ecological Safety of Coastal and Shelf Zones of Sea and Comprehensive Use of Shelf Resources]. Sevastopol: ECOSI-Gidrofizika. Iss. 26, vol. 1, pp. 212-216 (in Russian).
  15. Ovsyany, E.I., Kemp, R.B., Repeitin, L.N. and Romanov, A.S., 2000. [Hydrological and Hydrochemical Regime of the Sevastopol Bay under Conditions of Anthropogenic Impact (According to Observations in 1998–1999)]. In: MHI, 2000. *Ekologicheskaya Bezopasnost' Pribrezhnykh i Shel'fovykh Zon i Kompleksnoe Ispol'zovanie Resursov Shel'fa* [Ecological Safety of Coastal and Shelf Zones of Sea and Comprehensive Use of Shelf Resources]. Sevastopol: ECOSI-Gidrofizika. Iss. 1, pp. 79-103 (in Russian).
  16. Sovga, E.E., Mezentseva, I.V., Khmara, T.V. and Slepchuk, K.A., 2014. [On the Prospects and Possibilities for Assessing the Self-Cleaning Capacity of the Water Area of the Sevastopol Bay]. In: MHI, 2014. *Ekologicheskaya Bezopasnost' Pribrezhnykh i Shel'fovykh Zon i Kompleksnoe Ispol'zovanie Resursov Shel'fa* [Ecological Safety of Coastal and Shelf Zones of Sea and Comprehensive Use of Shelf Resources]. Sevastopol: ECOSI-Gidrofizika. Iss. 28, pp. 153-164 (in Russian).
  17. Sovga, E.E. and Khmara, T.V., 2020. Influence of the Chernaya River Runoff during High and Low Water on the Ecological State of the Apex of the Sevastopol Bay Water Area. *Physical Oceanography*, 27(1), pp. 28-36. doi:10.22449/1573-160X-2020-1-28-36
  18. Gordina, A.D., Pavlova, E.V., Kemp, R.B., Wilson, J.G., Repeitin, L.N., Ovsyany, E.I., Romanov, A.S., Min'kovskaya, R.Ya., Krasnovid, I.I. [et al.], 2001. The Most Important Sources of Pollution of the Marine Environment of the Coastal Zone of Sevastopol. In: MHI, 2001. *Ekologicheskaya Bezopasnost' Pribrezhnykh i Shel'fovykh Zon i Kompleksnoe Ispol'zovanie Resursov Shel'fa* [Ecological Safety of Coastal and Shelf Zones of Sea and Comprehensive Use of Shelf Resources]. Sevastopol: ECOSI-Gidrofizika. Iss. 2, pp. 138-152 (in Russian).
  19. Simonov, A.I. and Ryabinin, A.I., eds., 1996. [*Hydrometeorology and Hydrochemistry of Seas. Vol. 4. The Black Sea. Iss. 3. Modern State of the Black Sea Water Pollution*]. Sevastopol: ECOSI-Gidrofizika, 230 p. (in Russian).
  20. Ivanov, V.A., Ovsyany, E.I., Repeitin, L.N., Romanov, A.S. and Ignatyeva, O.G., 2006. *Hydrological and Hydrochemical Regime of the Sevastopol Bay and Its Changing under Influence of Climatic and Anthropogenic Factors*. Sevastopol: MHI NAS of Ukraine, 90 p. Available at: [http://mhi-ras.ru/assets/files/gidrologo-gidrohimicheskij\\_rezhim\\_sevastopolskoj\\_buhty\\_2006.pdf](http://mhi-ras.ru/assets/files/gidrologo-gidrohimicheskij_rezhim_sevastopolskoj_buhty_2006.pdf) [Accessed: 28 February 2022] (in Russian).
  21. Gruzinov, V.M., Dyakov, N.N., Mezenceva, I.V., Malchenko, Yu.A., Zhohova, N.V. and Korshenko, A.N., 2019. Sources of Coastal Water Pollution near Sevastopol. *Oceanology*, 59(4), pp. 523-532. <https://doi.org/10.1134/S0001437019040076>



22. Pavlova, E.V., Ovsyany, E.I., Gordina, A.D., Romanov, A.S. and Kemp, R.B., 1999. [Modern State and Tendencies of Change in Sevastopol Bay Ecosystem]. In: E. V. Pavlova and N. V. Shadrin, eds., 1999. [*Sevastopol Aquatory and Coast: Ecosystem Processes and Services for Human Society*]. Sevastopol: Akvavita Publ., pp. 70-94 (in Russian).
23. Mironov, O.G., Kirjukhina, L.N. and Alyomov, S.V., 2003. *Sanitary-Biological Aspects of the Sevastopol Bays Ecology in XX Century*. Sevastopol: ECOSI-Gidrofizika, 185 p. (in Russian).
24. Lopukhin, A.S., Ovsyany, E.I., Romanov, A.S., Kovardakov, S.A., Bryanzeva, Yu., Rylkova, O.A., Gavrilova, N.A., Gubanov, V.V., Lopukhin, S.A. [et al.], 2007. Seasonal Peculiarities of Hydrologic-Hydrochemical Structure of Sevastopol Bay Water, Microplankton and Distribution of Its Biochemical Components (the Black Sea, Observations of 2004–2005). In: MHI, 2007. *Ekologicheskaya Bezopasnost' Pribrezhnykh i Shel'fovykh Zon i Kompleksnoe Ispol'zovanie Resursov Shel'fa* [Ecological Safety of Coastal and Shelf Zones of Sea and Comprehensive Use of Shelf Resources]. Sevastopol: ECOSI-Gidrofizika. Iss. 15, pp. 74-109 (in Russian).
25. Mukhanov, V.S., Litvinyuk, D.A., Sakhon, E.G., Bagaev, A.V., Veerasingam, S. and Venkatachalapathy, R., 2019. A New Method for Analyzing Microplastic Particle Size Distribution in Marine Environmental Samples. *Ecologica Montenegrina*, 23, pp. 77-86. <https://doi.org/10.37828/em.2019.23.10>
26. Verzhetskaya, L.V. and Minkovskaya, R.Ya., 2020. Structure and Dynamics of Anthropogenic Load on the Coastal Zone of the Sevastopol Region. *Ecological Safety of Coastal and Shelf Zones of Sea*, (2), pp. 92-106. doi:10.22449/2413-5577-2020-2-92-106 (in Russian).
27. Moiseenko, O.G., Orekhova, N.A., Polyakova, A.V., Medvedev, E.V. and Konovalov, S.K., 2015. Indices and Indicators of the Environmental State of the Sevastopol Bay. *Vestnik Moskovskogo Universiteta. Seriya 5, Geografiya*, (4), pp. 42-49. Available at: <https://vestnik5.geogr.msu.ru/jour/article/view/155> [Accessed: 03 March 2022] (in Russian).
28. Ryabtsev, Yu.N., Verzhetskaya, L.V., Rauen, T.V., Tsyganova, M.V., Nikishin, V.V. and Bagaev, A.V., 2021. Search for an Optimal Configuration of Projected Municipal Sewerage Outfalls in the Sevastopol Bay using Computational Modelling and Geoinformation Analysis. *Ecological Safety of Coastal and Shelf Zones of Sea*, (1), pp. 111-128. doi:10.22449/2413-5577-2021-1-111-128 (in Russian).
29. Moreira-Turcq, P., Martin, J. M. and Fleury, A., 1993. Chemical and Biological Characterization of Particles by Flow Cytometry in the Krka Estuary, Croatia. *Marine Chemistry*, 43(1-4), pp. 115-126. [https://doi.org/10.1016/0304-4203\(93\)90219-E](https://doi.org/10.1016/0304-4203(93)90219-E)
30. Moreira-Turcq, P.F. and Martin, J.M., 1998. Characterisation of Fine Particles by Flow Cytometry in Estuarine and Coastal Arctic Waters. *Journal of Sea Research*, 39(3-4), pp. 217-226. [https://doi.org/10.1016/S1385-1101\(97\)00053-1](https://doi.org/10.1016/S1385-1101(97)00053-1)
31. Agagliate, J., Röttgers, R., Twardowski, M.S. and McKee, D., 2018. Evaluation of a Flow Cytometry Method to Determine Size and Real Refractive Index Distributions in Natural Marine Particle Populations. *Applied Optics*, 57(7), pp. 1705-1716. <http://doi.org/10.1364/AO.57.001705>
32. Raimondi, F.M., Trapanese, M., Franzitta, V., Viola, A. and Colucci, A., 2015. A Innovative Semi-Immergible USV (SI-USV) Drone for Marine and Lakes Operations with Instrumental Telemetry and Acoustic Data Acquisition Capability. In: IEEE, 2015. *OCEANS 2015 – Genova*. IEEE, pp. 1-10. doi:10.1109/OCEANS-Genova.2015.7271595

33. Geng, C., Li, G. and Xu, H., 2019. A Platform for Coastline Monitoring System by Unmanned Surface Vessel. In: IEEE, 2019. *3rd International Symposium on Autonomous Systems (ISAS)*. Shanghai, China: IEEE, pp. 177-180. doi:10.1109/ISASS.2019.8757775
34. Blaich, M., Wirtensohn, S., Oswald, M., Hamburger, O. and Reuter, J., 2013. Design of a Twin Hull Based USV with Enhanced Maneuverability. *IFAC Proceedings Volumes*, 46(33), pp. 1-6. <https://doi.org/10.3182/20130918-4-JP-3022.00056>
35. Vasilj, J., Stancic, I., Grujic, T. and Music, J., 2017. Design, Development and Testing of the Modular Unmanned Surface Vehicle Platform for Marine Waste Detection. *Journal of Multimedia Information System*, 4(4), pp. 195-204. <https://doi.org/10.9717/JMIS.2017.4.4.195>
36. Yoder, N., Preston, V. and Michel, A., 2019. The PEST: Platform for Environmental Sensing Technology. In: IEEE, 2019. *OCEANS 2019 - Marseille*. Marseille, France: IEEE, pp. 1-5. <https://doi.org/10.1109/OCEANSE.2019.8867366>
37. Pruidze, R.S. and Shishkin, E.M., 2020. Robotic Unmanned Water Laboratory for Monitoring Small Natural and Artificial Reservoirs. *Meteorologiya i Gidrologiya*, (11), pp. 122-124 (in Russian).
38. Osadchiev, A., Barymova, A., Sedakov, R., Zhiba, R. and Dbar, R., 2020. Spatial Structure, Short-Temporal Variability, and Dynamical Features of Small River Plumes as Observed by Aerial Drones: Case Study of the Kodor and Bzyp River Plumes. *Remote Sensing*, 12(18), 3079. <https://doi.org/10.3390/rs12183079>
39. Osadchiev, A. and Zavialov, P., 2019. Structure and Dynamics of Plumes Generated by Small Rivers. In: J. Pan and A. Devlin, 2019. *Estuaries and Coastal Zones – Dynamics and Response to Environmental Changes*. London: IntechOpen. <https://doi.org/10.5772/intechopen.87843>
40. Nikishin, V., Durmanov, M. and Skorik, I., 2020. Autonomous Unmanned Surface Vehicle for Water Surface Monitoring. *TransNav, the International Journal on Marine Navigation and Safety of Sea Transportation*, 14(4), pp. 853-858. doi:10.12716/1001.14.04.09
41. Nikishin, V., Durmanov, M. and Skorik, I., 2021. Low-Cost Unmanned Surface Vehicle for Autonomous Bathymetric Surveillance. In: S. Bauk and S. D. Ilčev, 2021. *The 1<sup>st</sup> International Conference on Maritime Education and Development*. Cham: Springer, pp. 83-91. [https://doi.org/10.1007/978-3-030-64088-0\\_8](https://doi.org/10.1007/978-3-030-64088-0_8)
42. Nikishin, V.V. and Durmanov, M.A., 2019. [The Structure of Low- and High-Level Software for an Unmanned Marine Vehicle]. In: A. A. Savochkin, 2019. *Modern Issues in Radioelectronics and Telecommunications “RT-2019”*. Sevastopol: SevSU, p. 74 (in Russian).
43. Shishkin, I.E., Grekov, A.N. and Nikishin, V.V., 2019. Intelligent Decision Support System for Detection of Anomalies and Unmanned Surface Vehicle Inertial Navigation Correction. In: IEEE, 2019. *2019 International Russian Automation Conference (RusAutoCon)*. Sochi: Institute of Electrical and Electronics Engineers Inc., pp. 1-6. doi:10.1109/RUSAUTOCON.2019.8867601
44. Rauen, T.V. and Bagaev, A.V., 2021. [Evaluation of the Concentration and Qualitative Composition of Suspended Matter in the Sevastopol Bay Using a Flow Cytometer]. In: Shirshov Institute of Oceanology RAS, 2021. *Complex Investigations of the World Ocean. Proceedings of the VI Russian Scientific Conference of Young Scientists, Moscow, April 18–24, 2021*. Moscow: Shirshov Institute of Oceanology RAS, pp. 302-303. doi:10.29006/978-5-6045110-3-9 (in Russian).
45. Marie, D., Partensky, F., Jacquet, S. and Vaulot, D., 1997. Enumeration and Cell Cycle Analysis of Natural Populations of Marine Picoplankton by Flow Cytometry Using the

- Nucleic Acid Stain SYBR Green I. *Applied and Environmental Microbiology*, 63(1), pp. 186-193. <https://doi.org/10.1128/aem.63.1.186-193.1997>
46. Gasol, J.M. and Del Giorgio, P.A., 2000. Using Flow Cytometry for Counting Natural Planktonic Bacteria and Understanding the Structure of Planktonic Bacterial Communities. *Scientia Marina*, 64(2), pp. 197-224. <https://doi.org/10.3989/scimar.2000.64n2197>
  47. Marie, D., Simon, N. and Vaulot, D., 2005. Phytoplankton Cell Counting by Flow Cytometry. In: R. A. Andersen, ed., 2005. *Algal Culture Techniques*. Amsterdam: Elsevier. Chapter 17, pp. 253-267.
  48. Mikhailova, É.N. and Shapiro, N.B., 2008. Reconstruction of the Space and Time Variability of Thermohaline Fields in the Sevastopol Bay. *Physical Oceanography*, 18(5), pp. 255-271. <https://doi.org/10.1007/s11110-009-9026-x>
  49. Belokopytov, V.N., Kubryakov, A.I. and Pryakhina, S.F., 2019. Modelling of Water Pollution Propagation in the Sevastopol Bay. *Physical Oceanography*, 26(1), pp. 3-12. doi:10.22449/1573-160X-2019-1-3-12
  50. Ovsyany, E.I. and Orekhova, N.A., 2018. Hydrochemical Regime of the River Chernaya (Crimea): Environmental Aspects. *Physical Oceanography*, 25(1), pp. 77-88. doi:10.22449/1573-160X-2018-1-77-88
  51. Sercu, B., Van De Werfhorst, L.C., Murray, J.L.S. and Holden, P.A., 2011. Terrestrial Sources Homogenize Bacterial Water Quality During Rainfall in Two Urbanized Watersheds in Santa Barbara, CA. *Microbial Ecology*, 62(3), pp. 574-583. <https://doi.org/10.1007/s00248-011-9874-z>
  52. Yeo, S.K., Huggett, M.J., Eiler, A. and Rappé, M.S., 2013. Coastal Bacterioplankton Community Dynamics in Response to a Natural Disturbance. *PLoS ONE*, 8(2), e56207. <https://doi.org/10.1371/journal.pone.0056207>
  53. Bondur, V.G., Ivanov, V.A., Dulov, V.A., Goryachkin, Yu.N., Zamshin, V.V., Kondratiev, S.I., Lee, M.E., Mukhanov, V.S., Sovga, E.E. and Chukharev, A.M., 2018. Structure and Origin of the Underwater Plume near Sevastopol. *Fundamentalnaya i Prikladnaya Gidrofizika*, 11(4), pp. 42-54. doi:10.7868/S2073667318040068 (in Russian).

*About the authors:*

**Andrei V. Bagaev**, Senior Research Associate, Marine Hydrophysical Institute of RAS (2 Kapitanskaya str., 299011, Sevastopol, Russian Federation), Ph. D. (Phys.-Math.), **ORCID ID: 0000-0003-4018-7642**, **ResearcherID: K-5373-2016**, **SPIN-code: 5426-7176**, a.bagaev1984@mhi-ras.ru

**Vladimir V. Nikishin**, Lead Engineer, Marine Hydrophysical Institute of RAS (2 Kapitanskaya str., 299011, Sevastopol, Russian Federation), Ph. D. (Tech.), nikishin\_v@mail.ru

**Tatiana V. Rauen**, Research Associate, A. O. Kovalevsky Institute of Biology of the Southern Seas, Russian Academy of Sciences (2 Nakhimova ave, Sevastopol, 299011, Russian Federation), **ORCID ID: 0000-0002-6757-7491**, **SPIN-code: 1868-3826**, taschi@mail.ru

**Lyudmila V. Verzhetskaya**, Lead Specialist, Marine Hydrophysical Institute of RAS (2 Kapitanskaya str., 299011, Sevastopol, Russian Federation), **ORCID ID: 0000-0002-1547-7966**, **ResearcherID: R-4253-2018**, **SPIN-code: 7309-7879**, ludmyla.ver@mhi-ras.ru

**Sergei V. Scherbachenko**, Lead Engineer, Marine Hydrophysical Institute of RAS (2 Kapitanskaya str., 299011, Sevastopol, Russian Federation), **SPIN-code: 6248-1224**, shcherbachenko\_sv@mhi-ras.ru

*Contribution of the co-authors:*

**Andrei V. Bagaev** – general scientific supervision of the study, formulation of the comprehensive study goal and objectives, discussion of the work results, data processing, editing of the manuscript and preparation of illustrations

**Vladimir V. Nikishin** – development, manufacturing, and programming of the instrument complex, sampling, analysis, and interpretation of physical data, discussion of the work results

**Tatiana V. Rauen** – formulation of the goal and objectives of a comprehensive study, discussion of the results of the work, processing, and analysis of biological data, editing the manuscript and preparing illustrations

**Lyudmila V. Verzhevskaya** – sampling, analysis, and interpretation of data, editing of the manuscript, discussion of the work results

**Sergei V. Scherbachenko** – planning and preparation of expeditions, sampling, discussion of the work results

*The authors have read and approved the final manuscript.*

*The authors declare that they have no conflict of interest.*